

Protecting  
Doors, People  
& Places



Tel: +44 (0)1302 364 666  
Fax: +44 (0)1302 364 777  
sales@intastop.com  
www.intastop.com

Follow us on:  
Twitter, Facebook, LinkedIn & Instagram



Protecting  
People



With over 25 years of being a market leader in the specialist field of anti-ligature, Intastop offer solutions that focus on prevalent issues such as safety, reduction of ligature, increased strength and abuse resistance, privacy, access control and compliance with building regulations.



## Contents

### Solutions

<b>SECURA™</b> Bedroom Solution	04-05
<b>SECURA™</b> Ensuite Solution	06-07
<b>SECURA™</b> Communal Area Solution	08-09

### Products

Post Formed Doors & Frames	10-11
Door Top Alarm Solution	12-13
<b>SECURA™</b> Hinge	14-15
<b>NEW</b> Shrouded Double Swing Hinge	16-17
Double Swing Hinge Solution	18-19
Removable Doorstops	20-21
<i>IVision</i>	22-23
<b>INTA</b> Glaze	24-25
IPC™ Anti-Ligature PVC Handrails	26-27
Solid Wood Handrails	28
<b>INTA</b> Switch	29
Anti-Ligature Locks	30
Protecting Doors and Places	31

Disclaimer: Please note that Intastop offers a range of measures designed to reduce the risk of self-harm or suicide, and does not offer any guarantee that it will not take place. The solutions have been designed as a deterrent only.

# SECURA™ Solution Bedroom

Providing a comfortable, relaxing and safe environment is essential to the well-being and progress of a service user's rehabilitation. Bedrooms should be an area of solace where care and safety is of upmost importance.

The door leading into the bedroom is pivotal to this, our solutions ensure instant access even in barricade situations, high visibility and full black out giving the user total privacy and a range of anti-ligature measures to ensure complete safety. All backed by the Intastop assurance of high quality and low maintenance.

## Featured Solutions

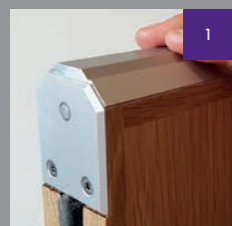

### 1 Door Top Alarm

Helps reduce the risk of potential suicide.

Tamper proof preventing false alarms.

Improves safety of patients in secure units.

Enables immediate staff response.

more on page 12-13



### 2 Privacy Vision Panels

**IVision**; Stylish vision panel providing up to 80% visibility.

**INTAGlaze**; Monitor patients easily and safely with up to 41% visibility.

**INTASwitch**; Switchable vision panel at the push of a button, 100% visibility.

more on page 22-25

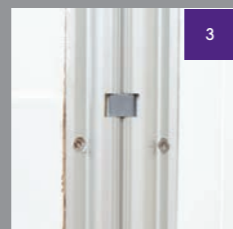

### 3 Continuous Geared Hinges

Double Swing Hinge; swift opening for emergency situations.

**SECURA™ Hinge**; helps reduce the risk of potential suicide and self harm.

more on page 14-19

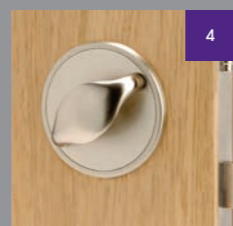

### 4 Anti-Ligature Locks

Bedroom Lockset – Anti-Ligature key operated roller bolt deadlock.

Communal Washroom – Anti-Ligature Lock Set with indicator.

more on page 30



### 5 Removable Doorstops

Removable Doorstop; Frame or stop mounted options to eliminate barricade situations.

Aluminium Doorstop; Durable and will not distort with moisture of fluctuations in temperature.

more on page 20-21

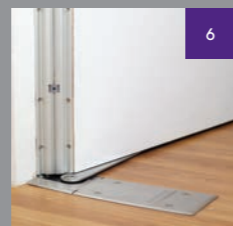

### 6 Concealed Door Closers

PERKO Powermatic Door Mounted Closer – can be positioned as low as 300mm from the base of the door, and works with the **SECURA™ Hinge**.

Concealed Door or Frame Mounted Closer – can be floor or frame mounted and works with the Double Swing Hinge.

more on page 14-19



Easy access in event of barricade



Increased visibility



Please note that Intastop offers a range of measures designed to reduce the risk of self-harm or suicide, and does not offer any guarantee that it will not take place. The solutions have been designed as a deterrent only.

# SECURA™ Solution Ensuite

Ensuites are a high privacy area. Service users and staff need to have confidence that this room will provide discretion and safety. To ensure these are achieved we, at Intastop, have developed a range of products that will offer both privacy and protection.

Our Post-Formed Doors offer a low maintenance highly resistant solution that provides moisture and water resistance as well as containing Hygienilac® - an antibacterial agent capable of killing 99.9% of harmful bacteria. Combined with our unique Anti-Ligature Door Top Alarm, Lock and Electrical Transfer Hinge we can offer a completely safe and secure ensuite door solution.



Improves safety of patients



Tamper proof preventing false alarms

## Featured Solutions

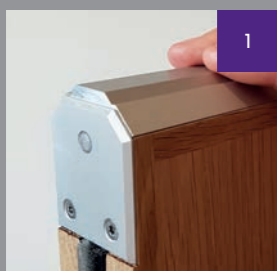

1

### Door Top Alarm

- Helps reduce the risk of potential suicide and self harm.
- Tamper proof preventing false alarms.
- Improves safety of patients in secure units.
- Enables immediate staff response.

more on page 12-13

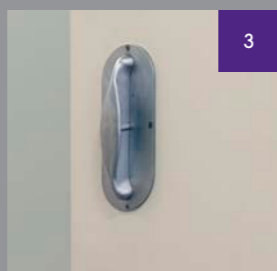

3

### Anti-Ligature Locks

- Bedroom Lockset - Anti-Ligature key operated roller bolt deadlock.
- Communal Washroom - Anti-Ligature Lock Set with indicator.

more on page 30



2

### Electrical Transfer Hinge

- Provides a concealed and vandal resistant method of transferring cable.
- Easy to maintain as fully accessible.
- Safe and secure power supply.
- Performance tested to 1.25 million cycles.

more on page 15

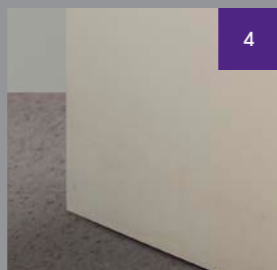

4

### Post-Formed Doors

- Complete encasement, leaving no exposed edges and providing optimal impact resistance.
- Improves lifespan of your door.
- Minimises infection - incorporates Hygienilac® anti-microbial additive.
- Moisture and water resistant.

more on page 10-11



Door Top Alarm 1

Electrical Transfer Hinge 2

Anti-Ligature Lock 3

Post-Formed-Door 4

Please note that Intastop offers a range of measures designed to reduce the risk of self-harm or suicide, and does not offer any guarantee that it will not take place. The solutions have been designed as a deterrent only.

# SECURA™ Solution Communal Area

Communal areas are often seen as the heart of a facility where many users, staff, family and friends pass through or meet. The touch points in these high traffic areas are subjected to high usage and often require more frequent maintenance.

Here at Intastop we have developed a range of solutions that will provide comfort safety and low maintenance as well as looking great! Our portfolio includes a collection of handrails incorporating the elegant, yet functional, Anti-ligature Wooden Handrails and PVC, a compilation of Vision Panels that provide up to 80% visibility or full black out depending on requirements and Continuous Hinges including the renowned SECURA™ and Double Swing Hinge.



Improves safety of patients



Continuous design no gaps

## Featured Solutions

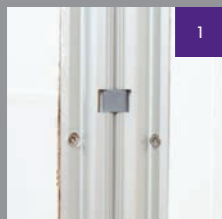

1

### Continuous Geared Hinges

Double Swing Hinge; swift opening for emergency situations.

SECURA™ Hinge; helps reduce patient suicide and self-harm.

more on page 14-19

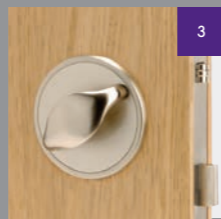

3

### Anti-Ligature Locks

Bedroom Lockset – Anti-Ligature key operated roller bolt deadlock.

Communal Washroom – Anti-Ligature Lock Set with indicator.

more on page 30



2

### Privacy Vision Panels

IVision; Stylish vision panel providing up to 81% visibility.

INTAGlaze; Monitor patients easily and safely with up to 41% visibility.

INTASwitch; Switchable vision panel at the push of a button, 100% visibility.

more on pages 22-25

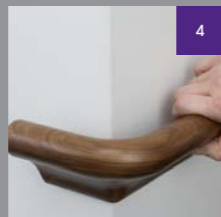

4

### Anti-Ligature Handrails

Anti-Ligature Solid Wood Handrail.

Anti-Ligature PVC Combi-Rail.

more on page 26-27

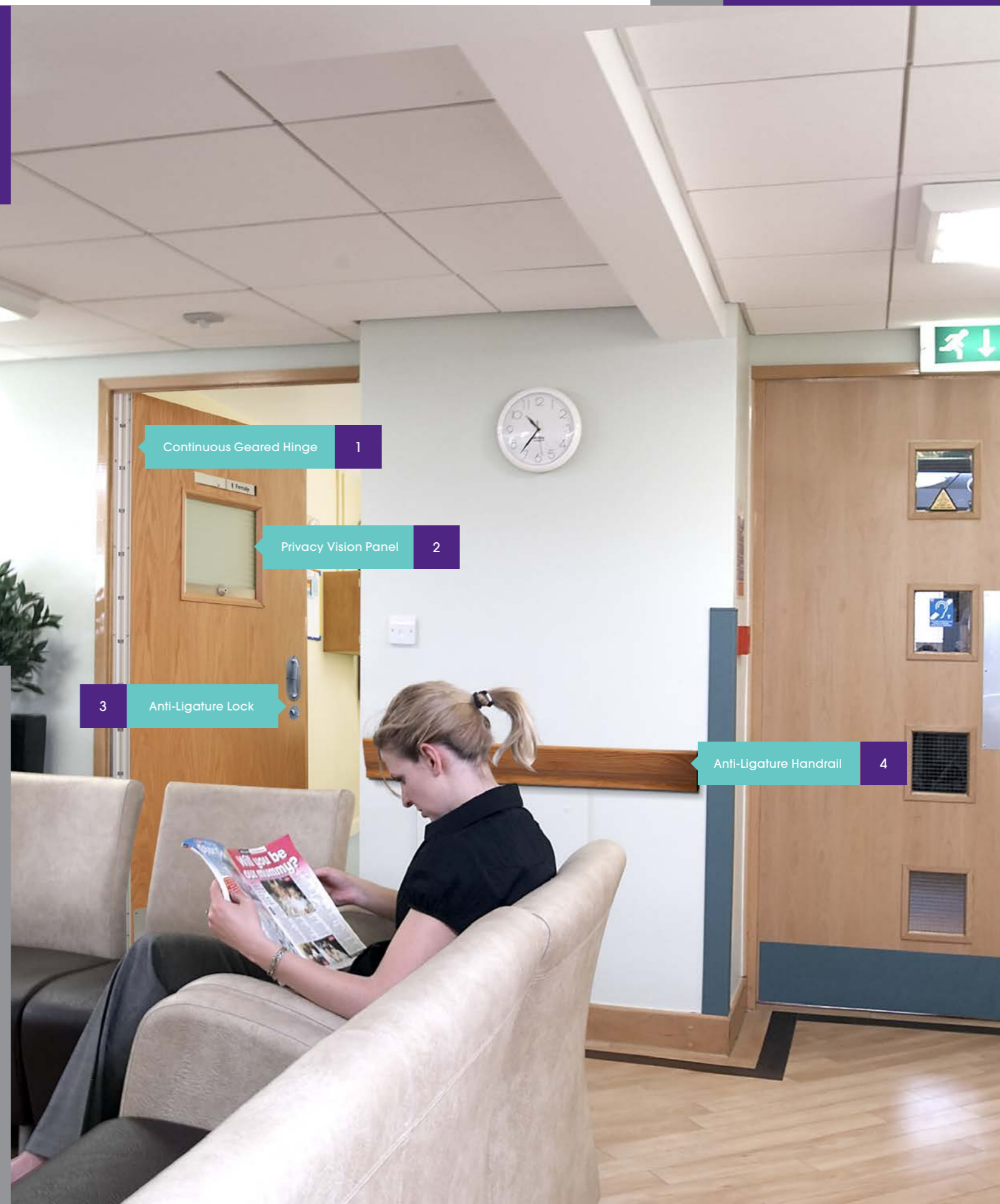

Continuous Geared Hinge 1

Privacy Vision Panel 2

3 Anti-Ligature Lock

Anti-Ligature Handrail 4

Please note that Intastop offers a range of measures designed to reduce the risk of self-harm or suicide, and does not offer any guarantee that it will not take place. The solutions have been designed as a deterrent only.

# Post-Formed Doors & Frames

Complete encasement of doors and frames.

Class 'O' Fire Rated; tested to BS476 Parts 6 & 7

Reduces maintenance costs

Impact and water resistant



Fire rated

Plastics forming technology means any shape or object can be completely encased with Intastop's Impact Protection Sheets, facilitating total or partial protection for doors and frames whilst meeting all the legislative requirements for health and safety.

The Intastop post-formed door is totally encased to its full height and width, leaving no exposed edges, to provide optimal impact resistance. Available in hygienic smooth or textured finish in a wide range of colours, it offers the ideal solution for doors between bedrooms, en-suites and corridor doors.

### Features

Antibacterial finish inc hygienlac®.

Minimises sharp/rough edges on timber.

Impact and water resistant.

### Finishes

Standard finish PVC-u, available in a wide range of colours.

Please contact our sales department for a full colour swatch.

### Benefits

Ensures staff and patient safety in the event of a fire by maintaining fire integrity of the door allowing safe evacuation.

Reduces maintenance costs by protecting the frame from damage occurring.

Maintains a clean safe environment ensuring staff and patient hygiene safety.

Keeps staff and patients safe by protecting them from exposed damaged timber edges.

Peace of mind that doors such as bathrooms are protected without the risk of swelling.

### Order details

Order code	Description	Size
FSA-PF	Antibacterial Textured Impact Sheet Post-formed	Please specify
FSS-PF	Smooth Impact Sheet Post-formed	Please specify

### Options

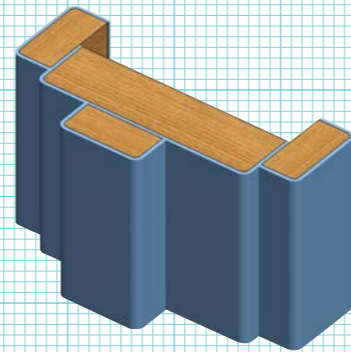

Standard Post-Formed Frame

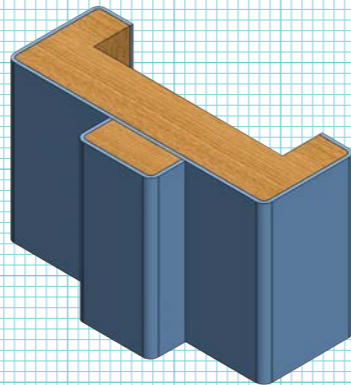

Integral Arc Frame

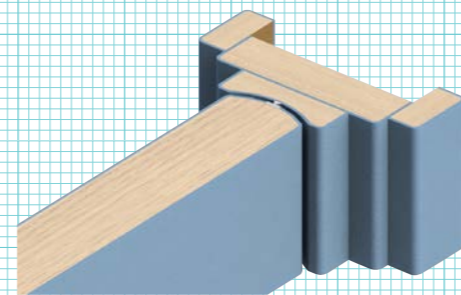

Post-Formed Door & Frame



Reduces maintenance costs

### Colours

Textured finishes



Smooth finishes



# Door Top Alarm Solution

Helps prevent suicide at the tops of doors.

- Improves safety of patients
- Enables immediate staff response
- Tamper proof preventing false alarms

## Revolutionary Door Top Alarm

This tamper proof system detects when weight is applied to the top of the door and has a variable alarmed delay setting between 5 and 30 seconds. The Door Top Alarm connects via mains power and is compatible with most staff attack systems. It can alert staff via audible alarm, visible light, staff indicator panel and via the pager or main computer.

If the top of the alarm is pressed nothing will happen until the programmed delay setting in the electronic box is activated. It has a three tiered LED system on the door top alarm which is mirrored on the electronic box, and optionally on nurse stations. LED lighting shows it working without setting the alarm off, helping with risk assessment period checks. LED is not visible to patients. An inspection magnet is used to aid installation and carry out risk assessments.

The electronic box is housed in ceilings/loft and connects to the mains power and staff attack system.

## Electrical Transfer Hinge

Power transfer to the door goes via Intastop's Electrical Transfer Hinge which ensures all cabling and electronics are concealed. Performance tested to 1.25 million cycles; it has a removable option, where the hinge is designed to be installed in 2 sections. This allows the current carrying cable to be serviced or replaced without removing the door from the frame making it ideal for use with Intastop's Door Top Alarm.

A commissioning and planned preventative maintenance programme is offered as an additional service.



New End Cap design for greater ligature resistance

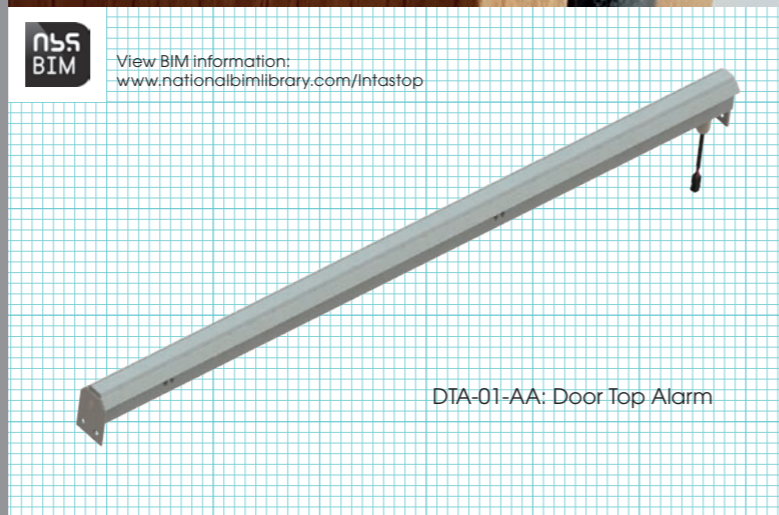

DTA-01-AA: Door Top Alarm

View BIM information: [www.nationalbimlibrary.com/Intastop](http://www.nationalbimlibrary.com/Intastop)

## Features

- FD30 Fire Rated. Tested to BS476: Part 20 & 22.
- Suitable for single and double acting door sets.
- Connects to existing staff attack system.
- Transfer wire tested to 3 million cycles with a 5 year warranty\*.
- Electrical Transfer Hinge is performance tested to 1.25 million cycles.

## Benefits

- Helps reduce the risk of potential suicide and self harm.
- Enables staff to respond immediately to attempted suicides and emergency situations.
- Easy to maintain as fully accessible without having to take the door off.
- Safe and secure power supply through hanging stile of the door.

## Finishes

Standard finish is Satin Anodised Aluminium (SAA).

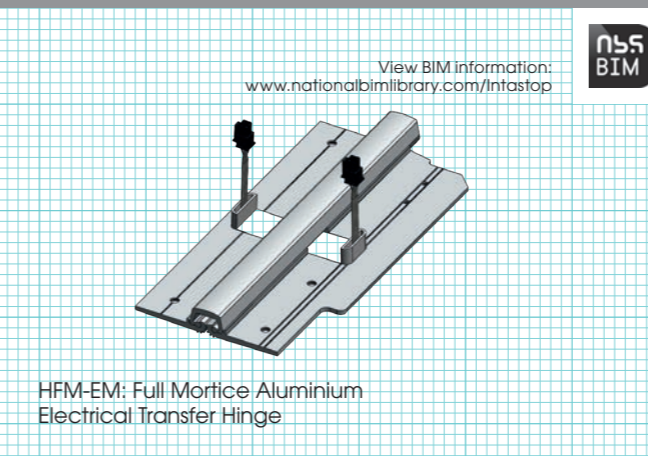

HFM-EM: Full Mortice Aluminium Electrical Transfer Hinge

## Order details (Door Top Alarm)

Order code	Description	Length (mm)
DTA-01-AA-44	Door Top Alarm to suit 44mm width door	Up to 950
DTA-01-AA-54	Door Top Alarm to suit 54mm width door	Up to 950
DTA-ECB	Door Top Alarm Electrical Control Box	N/A
DTA-MAGNET	Door Top Alarm Inspection Magnet	N/A
COMMISSIONING	Commissioning of Door Top Alarm +1 year Planned Maintenance	N/A

## Order details (Electrical Transfer Hinge)

Order code	Description	To Suit Door Width (mm)	Action	Duty	Length (mm)
HFM-01-EM	Full Mortice Electrical Transfer Hinge with smoke seal - 4 wire	44 or 54	Single Swing	Standard Heavy or Extreme	200
HFM-01-AA	Full Mortice Hinge	44 or 54	Single Swing	Standard Heavy or Extreme	2100 or 2400
HAL-DC-SAA	Anti-Ligature Aluminium Domed Cap	44 or 54	Single Swing	N/A	N/A
HDS-01-EM	Double Swing Electrical Transfer Hinge with smoke seal - 4 wire	44	Double Swing	Severe**	2100 or 2400
HDS-01-AA	Double Swing Hinge	44	Double Swing	Severe**	2100 or 2400

Standard Duty for doors up to 125kg in weight (95% of UK doors). Heavy Duty for doors up to 245kg in weight. Extreme Duty for doors up to 500kg in weight.

\*\*Intastop's Double Swing Hinge is designed for high impact areas and heavy doors up to 160kg, this heavy duty product has been tested to Severe Duty Rating DD171 and performance tested to European Standard EN1935.

\* Subject to Intastop's warranty policy.

Please note that Intastop offers a range of measures designed to reduce the risk of self-harm or suicide, and does not offer any guarantee that it will not take place. The solutions have been designed as a deterrent only.

# SECURA™ Hinge

Top-to-bottom hinge safety. Closing the gap on Safety and Aesthetics.

Fire tested to BS476: Part 20 & 22 for 30 & 60 minutes

Performance Tested to 1.5 million cycles

Grade 1 abuse tested



Fire rated



View BIM information:  
www.nationalbimlibrary.com/Intastop



HAL-AA: Full Mortice Anti-Ligature SECURA™ Hinge

## A Concealed Closer Solution

Combining the safety and efficiency of the SECURA™ Hinge with the power of a Perko Powermatic® Door Closer, this unique, hidden package provides a safe, reliable, high performance solution for a wide variety of health care situations. When used in conjunction with Intastop's SECURA™ Hinge the Perko Powermatic® Closer can be positioned as low as 300mm from the base of the door. The closer is Fire Tested to BS EN 1634 for 30 and 60 minutes. Opening forces comply with Approved Document M.

Intastop's SECURA™ Hinge can be used on new or existing doors and is applied so as to conceal both leaves. Unlike conventional hinges, the SECURA™ Hinge does not have a pin. It consists of two full height, paired and geared leaves. Each geared leaf rotates evenly from top to bottom riding on Delrin-Teflon bearings. These softened bearings greatly reduce the ligature between the bearing and hinge leaves which minimises potential self-harm in the open state (i.e. when rubbing wrist against hinge).

The Finger Safety SECURA™ Hinge eliminates the dangerous gap on the hinge side of the door preventing fingers being trapped. A durable, long-term solution lasting for the life time of the door.

### Features

Opens 180° in one direction, allowing door to fold back.

Tested to DHF TS 001:2013 B4 (0.5mm test wire).

FD30 & FD60 Fire Rated. Tested to BS476: Part 20 & 22.

Meets and exceeds BS EN:1935 (life cycle tested to 1.5 million cycles).

### Benefits

Helps reduce the risk of potential suicide and self harm.

Reduces your maintenance and overall lifecycle costs.

Gives your patients privacy.

### Finishes

Standard finish is Satin Anodised Aluminium (SAA).

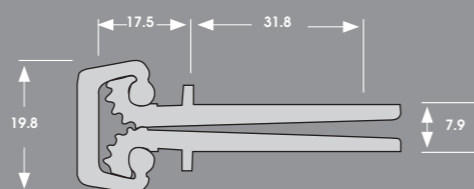

Standard SECURA™ Hinge

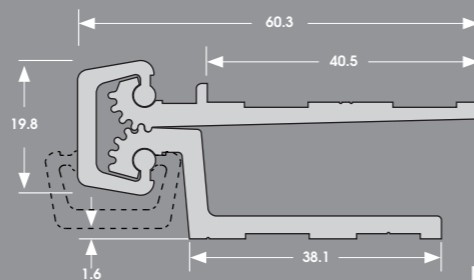

Finger Safety Hinge

### Order details

Order code	Description	Duty	Length (mm)
HAL-AA	Full Mortice Anti-Ligature Secura™ Hinge	Standard, Heavy or Extreme	2100 or 2400
HINGE-SEALPACK	Intastop Full Mortice Hinge Fire/Smoke Seal Pack FD30/FD60	N/A	2100 or 2400
PPO-01-AA	Perko Powermatic Door Closer	N/A	N/A
PPO-01-AA-FS	Perko Powermatic Free Swing Door Closer	N/A	N/A
HFF-01-DC	Finger Safety Hinge with Domed Cap	Standard or Heavy Duty	2100 or 2400

Standard Duty for doors up to 125kg in weight (95% of UK doors). Heavy Duty for doors up to 245kg in weight. Extreme Duty for doors up to 500kg in weight.

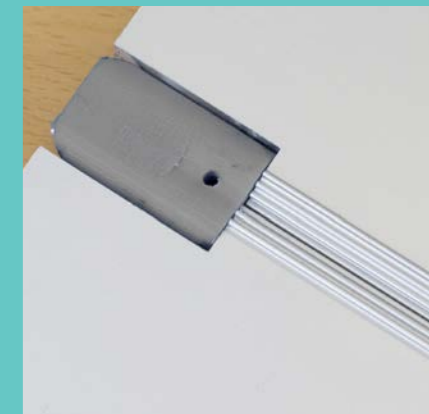

Anti-Ligature Tip minimises potential gap

### New softened bearing

The new Softened Bearing greatly reduces the ligature between the bearing and hinge leaves and greatly minimises potential self-harm issues in the open state (i.e. when rubbing the wrist against the hinge).



New bearing eradicates the gap

Please note that Intastop offers a range of measures designed to reduce the risk of self-harm or suicide, and does not offer any guarantee that it will not take place. The solutions have been designed as a deterrent only.



**NEW**

# Shrouded Double Swing Hinge

Finger Safe Hinge for Swift opening in emergency situations

- Finger Safe –complies to UK & European standards
- Swings 90° in both directions or 180° in one direction
- Fire Tested to BS476:Part 20 & 22 for 30 minutes

## Shrouded Double Swing Hinge

The Intastop New Shrouded Double Swing Continuous Geared Hinge is encased in a shroud providing improved Finger safety which complies with UK & European standards. It helps reduce the risk of ligature and self harm, eliminates doors splitting or dropping on impact (unlike Pivots) and is quick and easy to install with no rounding of doors or scalloping of frames required.

The Intastop Shrouded Double Swing Continuous Geared Hinge can be combined with Intastop's Removable Doorstop, to offer a unique patented anti-barricade package providing quick opening in emergency situations, helping reduce the risk of ligature and is ideal for doorsets that need to swing 90° in both directions or 180° in one direction.

The hinge has its gears and intumescent encased. It is available in a variety of finishes including anodised aluminium, powder coated or wood effect. The shroud has zero pinch points making it entirely safe for fingers and reduces ligature opportunity. For anti-barricade solutions the Double Swing Hinge works with the Removable Doorstop and Concealed Door Closer.

An electrical transfer version is also available and can be paired with Intastop's Door Top Alarm (see Page 12).

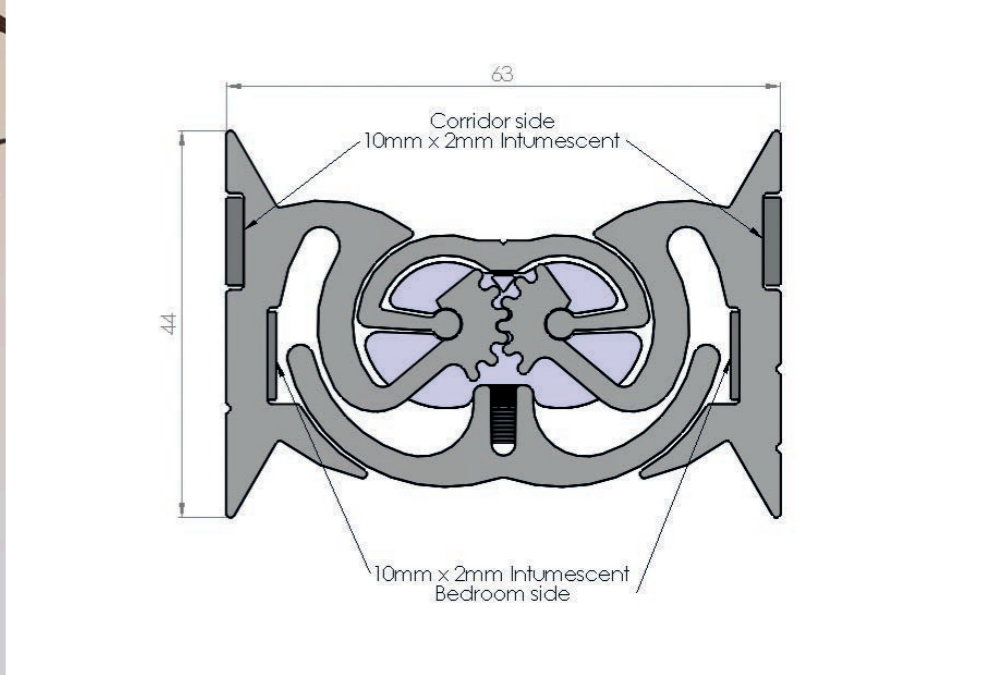
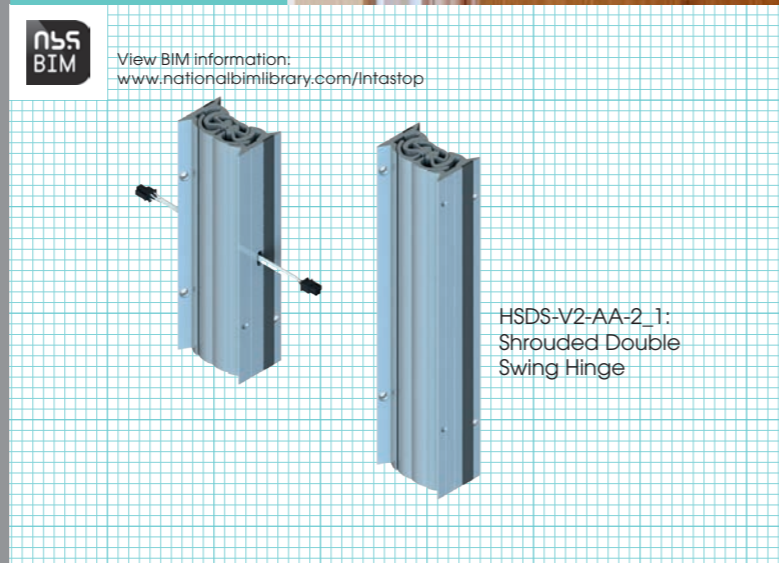
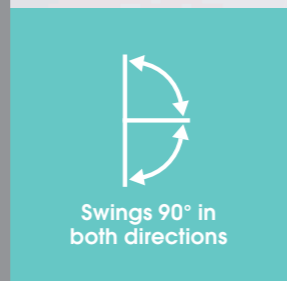
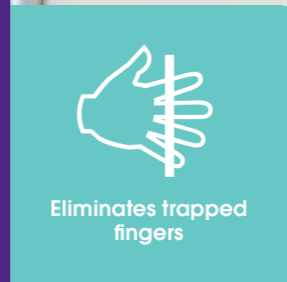

### Features

- Finger Safe – Complies to UK & European Standard.
- Swings 90° in both directions or 180° in one direction.
- Fire Tested to BS 476: Part 20 & 22 for 30 minutes.
- Abuse Tested to Adult Medium Secure Abuse Test.

### Benefits

- Helps reduce the risk of potential suicide and self harm.
- Reduces maintenance and overall lifecycle costs.
- Eliminates doors splitting or dropping (unlike Pivots).

### Finishes

Satin Anodised Aluminium as standard. Powder coated to any RAL number or wood effect available.

### Order details

Order code	Description	Duty	Door Rating
HSDS-V2-AA_2.1	Shrouded Double Swing Hinge – 44mm Door	Severe	160kg (grade 6)
Can be used with concealed closer if required:			
IDC-01-AA	Concealed Floor Mounted Door Closer	N/A	N/A
IDC-01-AA-INVERSE	Concealed Frame Mounted Door Closer	N/A	N/A

Please note that Intastop offers a range of measures designed to reduce the risk of self-harm or suicide, and does not offer any guarantee that it will not take place. The solutions have been designed as a deterrent only.

# Double Swing Hinge Solution

Swift opening for emergency situations.

- Swings 90° in both directions
- Fire tested to European Standard EN1634-1 2000 to 30 minutes
- Performance tested to European Standard BS EN:1935



Swings 90° in both directions

## Double Swing Hinge

This solution is ideal for doors that need to swing 90° in both directions (180°) and eliminates the possibility of pivot doors splitting on impact. It provides an ideal solution for busy corridor doors which are exposed to impact damage and toilet/shower room doors where there is a risk of barricade or patients collapsing in the room. The Double Swing Hinge is designed for 44mm doors; for doors greater than 44mm an additional packer piece is available, which allows the hinge to fully open 90° in both directions.

## Concealed Closer

Mental health has special dispensation which states a closer can be exempt on fire doors to bedrooms in mental health accommodation (HTM05-02). Intastop are now able to give end users the choice. The patented Double Swing Hinge works with a concealed floor or frame mounted closer meaning there is the option that combines both reduced ligature and the possibility for a closer for bedrooms in mental health applications. This anti-ligature closer has a closing force size 3-6 and is suitable for leaf widths up to 1100mm. For further information please see the Intastop website [www.intastop.com](http://www.intastop.com).

## Order details

Order code	Description	Duty	Length (mm)
HDS-01-AA-AL-SS	Double Swing Hinge with Smoke seal Anti Ligature - 44mm Door	Severe	2100 or 2400
HDS-01-PACKER	Sapele Packer for Double Swing Hinge on Doors greater than 44mm	N/A	44 x 5
IDC-01-AA	Concealed Floor Mounted Door Closer & Arm Kit	N/A	N/A
IDC-01-AA-ARM	Arm Kit for Concealed Floor Mounted Close	N/A	N/A
IDC-01-AA-INVERSE	Concealed Frame Mounted Door Closer	N/A	N/A
411ARL-DS	Non-Handed Full Mortice Automatic Door Bottom, up to 19mm gap seal	N/A	838, 915, 1000, 1200



## Features

- Sight proof design (no gaps in hinge).
- Achieved Severe Duty Impact rating DD171.
- Performance tested to BS EN:1935.
- UK Patent GB 2451 276A.
- Tested to DHF TS 001:2013 B4 (0.5mm wire test).

## Benefits

- Gives patients privacy by removing usual gap between the door and frame.
- Helps reduce the risk of potential suicide and self harm.
- Reduces your maintenance and lifecycle costs.
- Light and easy to use for patients that are infirm or elderly.

## Finishes

Standard finish is Satin Anodised Aluminium (SAA).

## Anti-Barricade

Combining the Intastop Double Swing Continuous Geared Hinge and Removable Doorstop, this unique patented anti-barricade package offers quick opening in emergency situations.

## Improved Acoustic Performance

For improved acoustic performance a Full Mortice Automatic Door bottom is available to suit the Double Swing Hinge.

View BIM information:  
[www.nationalbimlibrary.com/Intastop](http://www.nationalbimlibrary.com/Intastop)

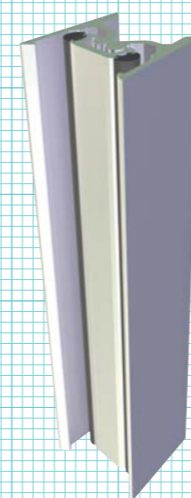

HDS: Double Swing Hinge

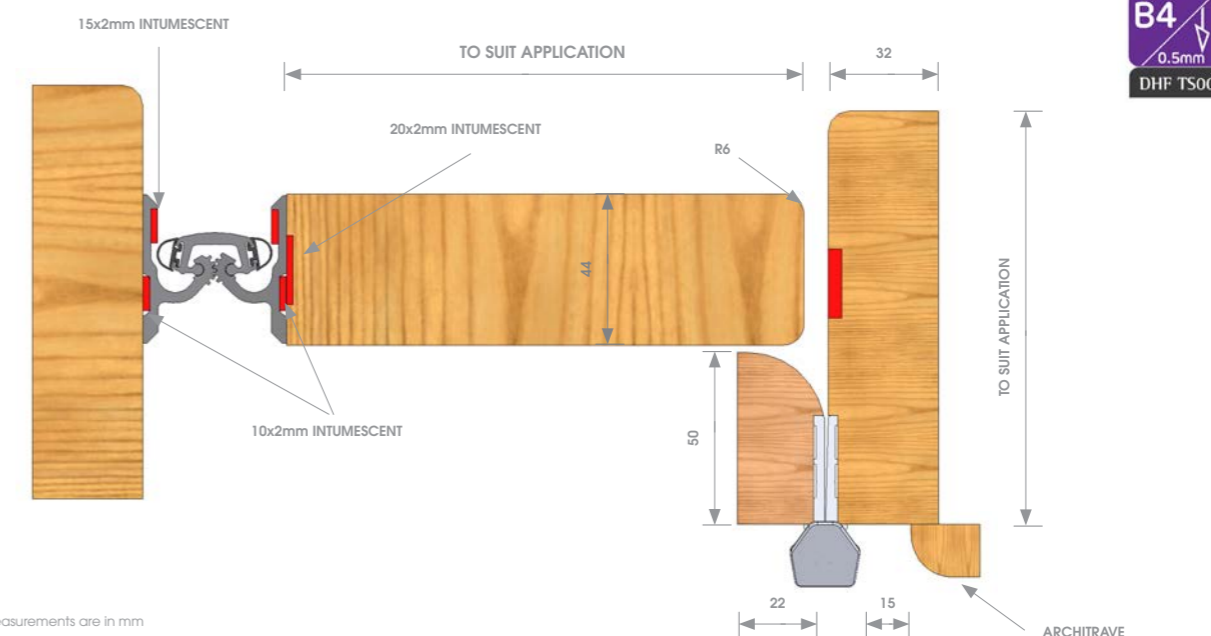

\*Please note measurements are in mm

Intastop's Double Swing Hinge is designed for high impact areas and heavy doors up to 160kg, this heavy duty product has been tested to Severe Duty Rating DD171 and performance tested to European Standard EN1935.

Please note that Intastop offers a range of measures designed to reduce the risk of self-harm or suicide, and does not offer any guarantee that it will not take place. The solutions have been designed as a deterrent only.

# Removable Doorstops

Helps eliminate barricade situations.

Easy access in event of barricade

Fire Rated EN1634-1 2000

Universal key

## A safe and rapid solution

Based upon Intastop's experience in the reduced ligature market and designed in conjunction with a leading Mental Health Trust, this full-length, fire rated doorstop is ideal for bedroom and en-suite doors in psychiatric accommodation, nursing homes and many disabled facilities including toilet doors.

## Solves barricade problems

The Intastop Removable Doorstop provides quick emergency outward opening operation of doors that normally open inwards, helping to resolve a number of problem areas including the elimination of barricade situations. Suitable for pivot or floor sprung hinges as well as Intastop Double Swing Hinge.

## Aluminium option

The Aluminium Intastop Removable Doorstop provides quick, easy emergency outward opening operation of doors that normally open inwards. Suitable for pivot, floor spring and Intastop Double Swing Hinges. It is durable and will not distort with moisture or fluctuations in temperature.

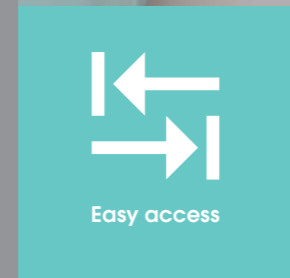

Removable Doorstop  
Hardwood - Frame  
Mounted

## Features

- Secure Dual Point Locking System.
- Anti-ligature tested to DHF TS 001:2013 B4 (0.5mm test wire).
- Universal key fits both Removable Doorstop & Privacy Vision Panel.
- FD30 fire rated. Tested to European Standard EN1634-1 2000.
- Achieved secure duty impact rating DD171.

## Benefits

- Easy access in the event of a barricade.
- Helps reduce the risk of potential suicide.
- Staff only need to carry one key to use on both Intastop Removable Door stop and Vision Panel (Lifeline Option).
- Reduces overall maintenance and lifecycle costs.
- Fast/safe response in an event of a barricade.

## Finishes

The standard finish is Tulipwood. Other hardwood timbers available on request. Also available in Satin Anodised Aluminium (SAA).

### Order details (Frame Mounted)

Order code	Description	Material	Mounting	Key Option	Size Dxl (mm)
RDS-01	Continuous Removable Doorstop	Tulip Wood	Frame	4mm	50 x 2100 or 2400
RDS-02	Continuous Removable Doorstop	Hardwood Timber	Frame	4mm	50 x 2100 or 2400
RDS-04	Continuous Removable Doorstop	Aluminium	Frame	4mm	50 x 2100 or 2400
RDS-05	Continuous Removable Doorstop	Tulip Wood	Frame	8mm	50 x 2100 or 2400
RDS-06	Continuous Removable Doorstop	Hardwood Timber	Frame	8mm	50 x 2100 or 2400

### Order details (Stop Mounted)

Order code	Description	Material	Mounting	Key Option	Size Dxl (mm)
RDS-03	Continuous Removable Doorstop	Aluminium	Stop	Keyless	50 x 2100 or 2400
RDS-07	Continuous Removable Doorstop	Tulip Wood	Stop	8mm	50 x 2100 or 2400
RDS-08	Continuous Removable Doorstop	Hardwood Timber	Stop	8mm	50 x 2100 or 2400
RDS-09	Continuous Removable Doorstop	Tulip Wood	Stop	Lifeline	50 x 2100 or 2400
RDS-10	Continuous Removable Doorstop	Hardwood Timber	Stop	Lifeline	50 x 2100 or 2400

Please note hardwood options are a natural product and if not stored correctly or are subject to fluctuations in temperature- moisture may distort. Intastop have no control over this once despatched, and thus cannot accept liability.



Removable Doorstop  
Hardwood -  
Stop Mounted

View BIM information:  
[www.nationalbimlibrary.com/Intastop](http://www.nationalbimlibrary.com/Intastop)

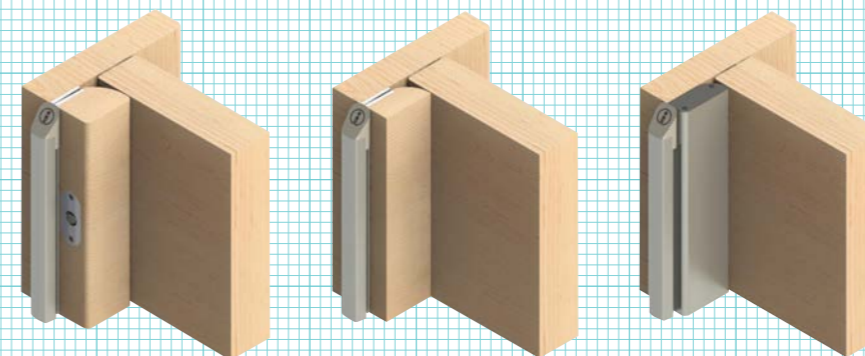

Removable Doorstop  
Timber Stop Mounted

Removable Doorstop  
Timber Frame Mounted

Removable Doorstop  
Aluminium Stop Mounted



Removable Doorstop  
Aluminium

Please note that Intastop offers a range of measures designed to reduce the risk of self-harm or suicide, and does not offer any guarantee that it will not take place. The solutions have been designed as a deterrent only.



Revolutionary



Stylish vision panel providing 80% visibility.

Provides 80% visibility

Fire tested to BS476 Part 20 & 22 for 30 and 60 minutes



80% visibility

IVision is a stylish clear to black vision panel which provides 92% visibility allowing patients to be easily monitored. It has been cycle tested to more than 250,000 cycles giving the end user peace of mind.

This quiet manually operated panel has an omni-directional feature which provides ease of use for left and right handed users. With the option of a Lifeline Key, staff only need to carry one key to operate multiple devices.

**Features**

Manually operated, no wiring/mains power required.

Interchangeable key to operate multiple devices.

Omni-Directional operator design.

Frameless design.

Cycle tested to greater than 250,000 cycles.

Patented design.

**Benefits**

Security and dignity of staff and service users assured using silent operation.

Monitor patients easier with near full visibility.

Easy for left or right hand users.

Staff only need to carry one key (lifeline) to operate multi devices.

Quiet operation (controlled closing of glass and optional plastic key).

**Operating mechanisms:**

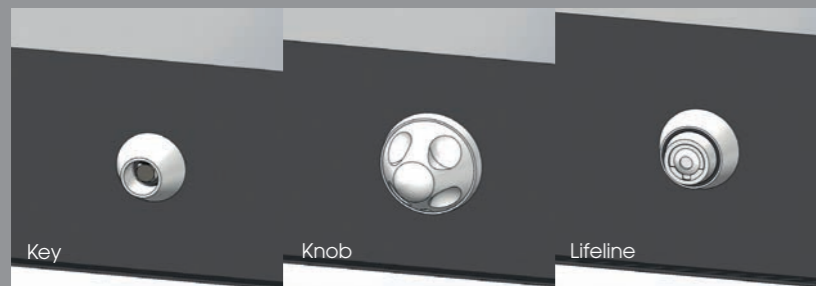

Key

Knob

Lifeline



View BIM information:  
[www.nationalbimlibrary.com/intastop](http://www.nationalbimlibrary.com/intastop)

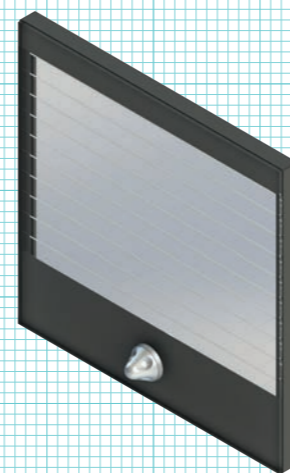

VIV-2 IVision Panel Open

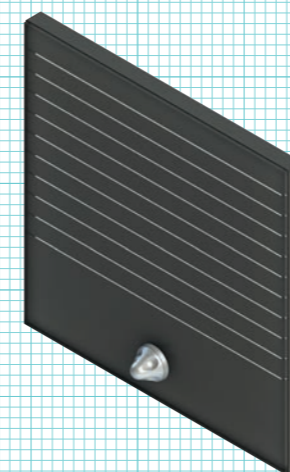

VIV-2 IVision Square Vision Panel Closed

**Finishes**

Standard finish is clear to black. Operating mechanisms are Satin Anodised Aluminium (SAA) finish as standard.

**Beading options**

Beading options include hardwood timber beading, PVC-u Clad Beading in a variety of colours to eliminate damage or Stainless Steel frame for mental health applications.

Oversized panels, up to 0.32m<sup>2</sup> and smaller ones available.

**Order details**

Order code	Description	Size HxW (mm)
VP-IV-1	IVision Rectangular Vision Panel	804 x 254
VP-IV-2	IVision Square Vision Panel	404 x 404
VP-IV-3	IVision Rectangular Vision Panel	404 x 254
VP-IG-SS	Stainless Steel Surround	804 x 254, 404 x 404, or 404 x 254

Please note that Intastop offers a range of measures designed to reduce the risk of self-harm or suicide, and does not offer any guarantee that it will not take place. The solutions have been designed as a deterrent only.

**NEW**

# INTAGlaze

For assessing and preventing potential self-harm risks.

Staff override on operating mechanism

Up to 41% visibility

Fire rated BS476 Part 20 & 22



Up to 41% visibility

INTAGlaze is a tried and tested vision panel that ensures the security and dignity of both staff and service users. The quiet, manually operated panel requires absolutely no wiring or mains power; making the door installation process and ongoing maintenance costs hassle free and cost effective.

DIGIGlaze, based on the tried and tested INTAGlaze but with bespoke design offers more capabilities for design integration into current or proposed interior schemes.

Fire rated and non-fire rated vision panels are available. For a more robust solution a thicker glass or a solid 6mm thick Perspex is recommended. INTAGlaze Privacy Vision Panels are as standard rectangular 254 x 804mm, 254 x 404mm, or 404 x 404mm square. Other sizes available on request. Panels have the option of an auto close feature.

### Beading options

Beading options include hardwood timber beading, PVC-u Clad Beading in a variety of colours to eliminate damage or Stainless Steel frame for mental health applications.

Oversized panels, up to 0.32m<sup>2</sup> and smaller ones available.

### Order details

Order code	Description	Size HxW (mm)
VP-IG-1	INTAGlaze Rectangular Vision Panel	804 x 254
VP-IG-2	INTAGlaze Square Vision Panel	404 x 404
VP-IG-3	INTAGlaze Rectangular Vision Panel	404 x 254
VP-IG-SS	Stainless Steel Surround	804 x 254, 404 x 404, or 404 x 254

Intastop Privacy Vision Panels are available with the option of Scotshield Ultra Safety film or with a solid 6mm thick perspex frontage.



DIGIGlaze offering bespoke design

### Operating mechanisms:



### Features

- Lifeline Key option operates the full doorset.
- Omni-Directional Operator Design.
- Frameless design.
- Cycle Tested to greater than 250,000 cycles.
- Variety of ironmongery options.

### Benefits

- Monitor patients easily and safely whilst still allowing level of privacy.
- Staff only need to carry one key to use on both Intastop Removable Door stop and INTAGlaze Panel (Lifeline Key Option).
- Easy for staff to use whether right or left handed.
- Ensures staff and patient safety in the event of a fire by maintaining fire integrity of the door allowing safe evacuation.
- Peace of mind that the panel will last the life time of the door.
- Confidence that Intastop will address any mechanical defects.
- Choose the ironmongery to suit your needs.

### Finishes

- Etched Strip on standard vision panels is Pearl.
- Other colours and/or graphic designs available.
- Vision panels are available in a variety of colours to brighten rooms up, coordinate with existing colour schemes and can be used to differentiate vision panel from the door.
- Operating mechanisms are Satin Anodised Aluminium (SAA) finish as standard.

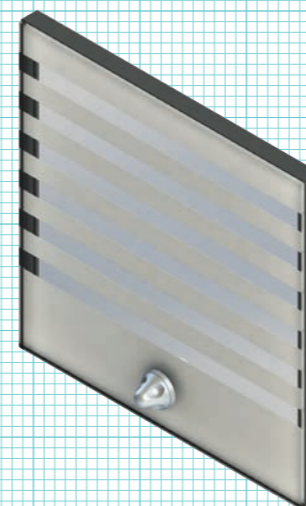

VIG-2: INTAGlaze Square Vision Panel

### Beading options:

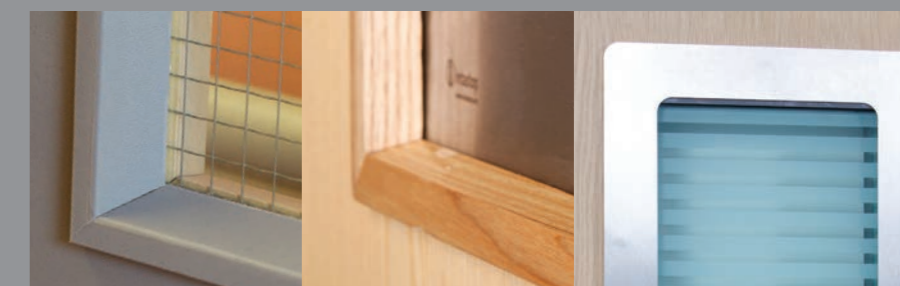

PVC-u Clad

Hardwood

Stainless steel

Please note that Intastop offers a range of measures designed to reduce the risk of self-harm or suicide, and does not offer any guarantee that it will not take place. The solutions have been designed as a deterrent only.



# IPC™ Anti-Ligature PVC Handrails

Safety and hygiene for mental health applications.

Designed to meet the Equality Act 2010 and HBN 00-04 Guidelines

Impact resistant

Available in a wide range of colours

The IPC® range of Anti-Ligature Handrails have been specifically developed for use in all mental health applications where there is a risk of ligature. Designed to be fixed without leaving a gap behind the rail, it features a continuous full length bracket which greatly reduces any potential ligature risk.

Offering comfortable grip dimensions to provide good pedestrian support and safety, the Intastop Anti-Ligature Handrail has a larger surface area than a normal hand rail. Hygienic and easy to clean, it is also designed to offer protection against impact from wheeled traffic.



Continuous design  
no gaps

### Features

- Continuous design, no gaps in between brackets.
- Impact resistant.
- Easy to clean; resists fungal and bacterial growth.
- Comfortable grip diameter and thumb groove.
- Available in a wide range of colours.

### Benefits

- Keeps patients and staff safe by giving them handrail support.
- Provides comfortable safe grip and not cold to the touch.
- Maintains a hygienic safe environment.
- Aids visually impaired people with colour contrast to the wall.
- Reduce maintenance costs by preventing wall damage.

### Finishes

Standard finish is PVC-u, available in a wide range of colours. Please contact our sales department for a full colour swatch.



Available in a wide range of colours

800 Handrail with Anti-ligature Combi-Rail

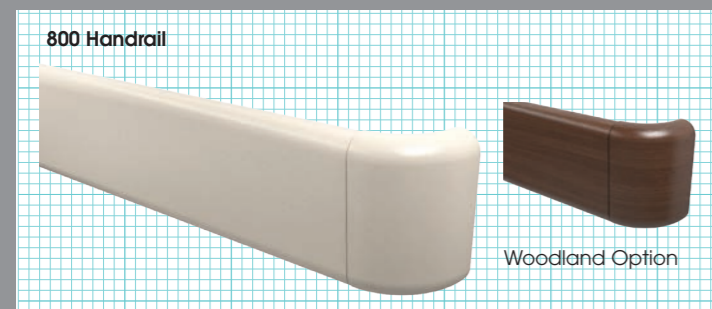

1000 Handrail with Anti-ligature Combi-Rail

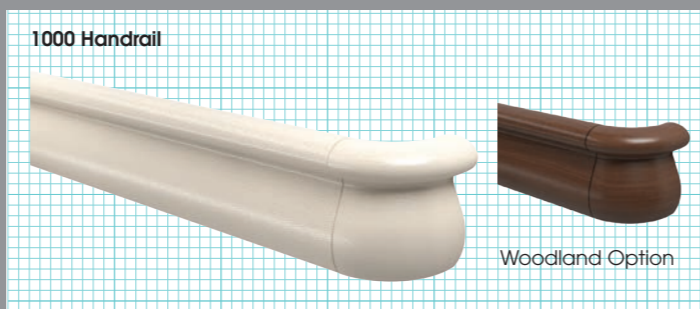

1200 Combined Handrail with Anti-ligature Combi-Rail

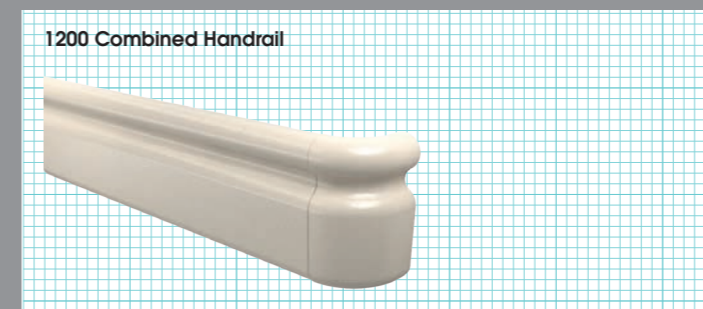

3130 Oval Combined Handrail with Anti-ligature Combi-Rail

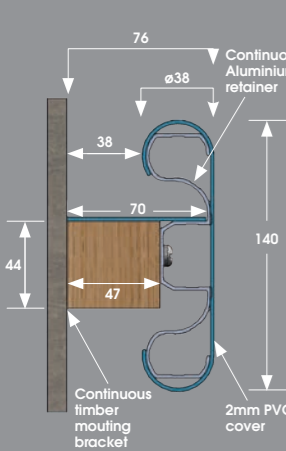

#### Order details

Order code	Description	Size HxL (mm)
I-HR-800 & WAL-01	800 Combined Handrail - Timber baton & PVC-u cover	140 x 3660

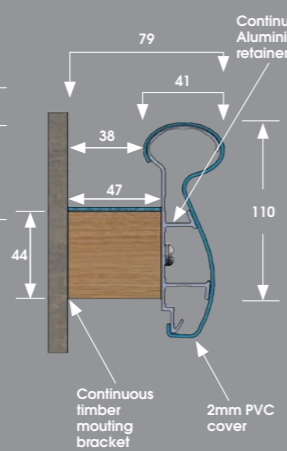

#### Order details

Order code	Description	Size HxL (mm)
I-HR-1000 & WAL-02	1000 Combined Handrail - Timber baton & PVC-u cover	110 x 3660

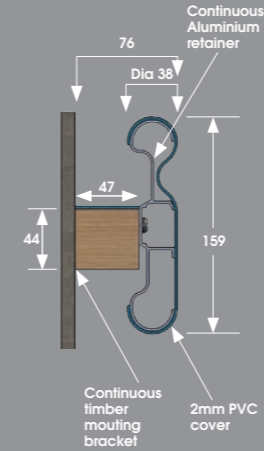

#### Order details

Order code	Description	Size HxL (mm)
I-HR-1200 & WAL-01	1200 Combined Handrail - Timber baton & PVC-u cover	159 x 3660

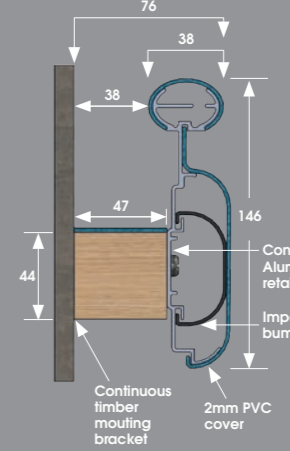

#### Order details

Order code	Description	Size HxL (mm)
I-HR-3130 & WAL03	3130 Oval Handrail - Timber baton & PVC-u cover	159 x 3660

Please note that Intastop offers a range of measures designed to reduce the risk of self-harm or suicide, and does not offer any guarantee that it will not take place. The solutions have been designed as a deterrent only.

### Colours

Handrail finishes





# Solid Wood Handrails

High quality handrails.

- Designed to meet HBN 00-04 guidelines
- Antibacterial coating
- High quality wood finish



Intastop's range of Anti-Ligature Solid Wood Handrails offer premium quality as well as antibacterial properties. Available in a wide range of wood finishes clients can be assured this product will give a prestige feel to their environment.

Choose from two options: Designed to meet HBN 00-04 guidelines or; designed to ascend up stairways as well as fitting as standard horizontal.

## Options

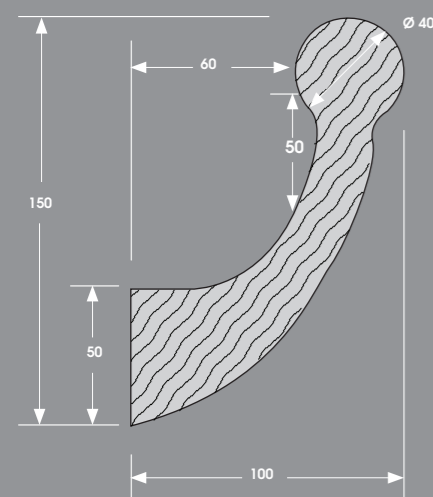

HBN 00-04  
ICRW-04-DM Anti-Ligature HBN 00-04 Handrail

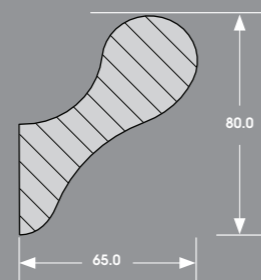

ICRW-04 Ant-Ligature Handrail (ability to ascend upstairs).

## Features

Full hand grab, option available designed to meet HBN 00-04 guidelines.

Option available with ability to ascend.

## Benefits

- Maintains a hygienic safe environment for patients and staff.
- Provides comfortable safe grip for patients and staff.
- Achieve a high quality environment.
- Gives handrail support on stairways.

## Finishes

Solid wood available in a range of finishes including Ash, Oak, Sapele, Maple, Cherry, Beech, Black Walnut and Iroko. Option of lacquered antibacterial coating.

## Order details

Order code	Description	Length (mm)
ICRW-04-DM	Anti-Ligature HBN 00-04 Solid Wood Handrail	3000
ICRW-04	Anti-Ligature Solid Wood Combined Hand/Protection Rail	3000
ICRW-04-LR	Anti-Ligature Solid Wood Left Hand Wall Return	N/A
ICRW-04-RR	Anti-Ligature Solid Wood Right Hand Wall Return	N/A
ICRW-04-RA	Solid Wood Ramp Rise	TBA

Please specify required colour when ordering. Ends and returns are bespoke and made to order.

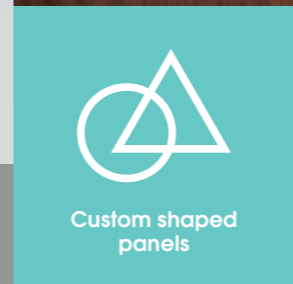

NEW

# INTASwitch

Switchable vision panel at the push of a button.

- Provides 100% visibility
- Fire tested to BS476 Part 20 & 22 for 30 and 60 minutes
- Custom shaped panels



INTASwitch is a switchable vision panel, allowing discreet visibility into/out of a room at the push of a button. In its frosted, unpowered state the panel acts as an opaque blind, giving the room complete privacy.

While the button is pressed, the film becomes clear, allowing the room to be checked without needing to open the door or disturb occupants. Standard sizes are available, or for bespoke projects Switchable Vision Panels can be cut to your precise requirements.

For the mains power option Intastop's Electrical Transfer Hinge provides a concealed and vandal resistant method of transferring cable. This ensures all cabling for the INTASwitch to the door is concealed.

## Features

- Mains power or battery operated (Battery is normally in closed state).
- Hidden wiring for mains power version via electrical transfer hinge Switching - < 1 second.
- Available in any size and numerous creative shapes.
- Various operating mechanisms including remote control.
- Can be linked to data recording devices.

## Benefits

- Security and dignity of staff and service users assured using a silent operation.
- Monitor patients easier with increased visibility.
- Size and shape tailor made to clients desire.

## Finishes

- Standard finish is clear to opaque. Coloured panels (grey, bronze, blue or green) available on request.
- Standard finish is satin stainless steel.

## Order details

Order code	Description	Size HxW (mm)
VIS-1	INTASwitch Rectangular Vision Panel	800 x 250
VIS-2	INTASwitch Square Vision Panel	400 x 400
VIS-3	INTASwitch Rectangular Vision Panel	400 x 250
VIG-SS	Stainless Steel Surround	800 x 250, 400 x 400, or 400 x 250

Above are standard sizes but any other size available on request.



Please note that Intastop offers a range of measures designed to reduce the risk of self-harm or suicide, and does not offer any guarantee that it will not take place. The solutions have been designed as a deterrent only.



Please note: Hardwood options are a natural product and if not stored correctly are subject to fluctuations in temperature/moisture and may distort. Intastop have no control over this once despatched, and thus cannot accept liability.

# Anti-Ligature Locks

A safer environment for those in special care.

-  Reduces risk of client self-harm
-  Allows staff flexibility of choice based on individuals
-  Ensures privacy yet provides a level of security

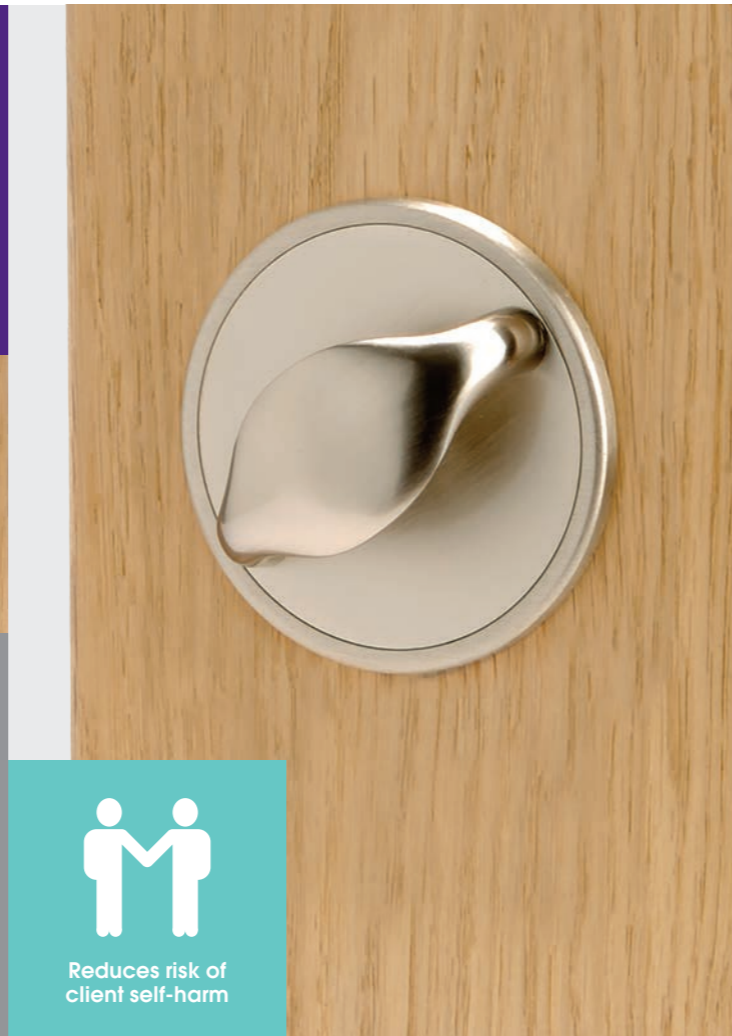

Reduces risk of client self-harm

Helping to ensure safer and more secure accommodation solutions, Anti-Ligature Lock Sets feature an integral staff key control facility. The use of the key in the external cylinder will override any action of the internal thumb turn.

All Lock Sets are designed to provide the client with privacy and dignity, yet at the same time reduce the risk of self harm.

A fully comprehensive range of Lock Sets are available, incorporating specially designed roller bolt deadlocks and auto deadlocking night latch to suit the wide variety of applications in a mental health ward.

## Features

- Unique reduced ligature thumb turn with integral pull.
- Choice of reduced ligature pull handles.
- Range of specialist lock cases.
- Holdback facility on certain locks.
- Lock cases have integral key control.
- Tamper proof fixings.
- Lock sets operate with any euro profile cylinder.
- Staff access at all times via external cylinder.

## Benefits

- Reduces risk of client self harm and barricade situation.
- Allows staff flexibility of choice based on individuals.
- Ensures privacy yet provides a level of security.

## Finishes

- Standard finish is Satin Stainless Steel.

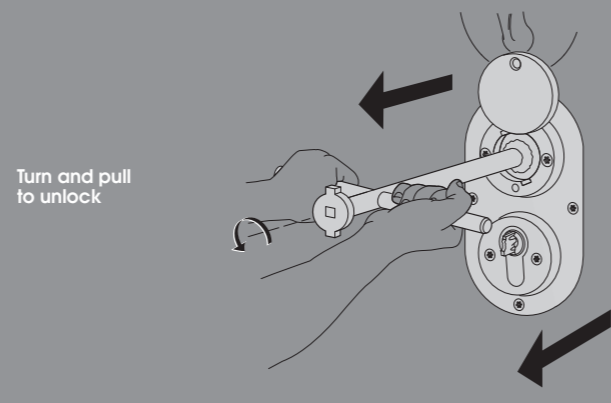
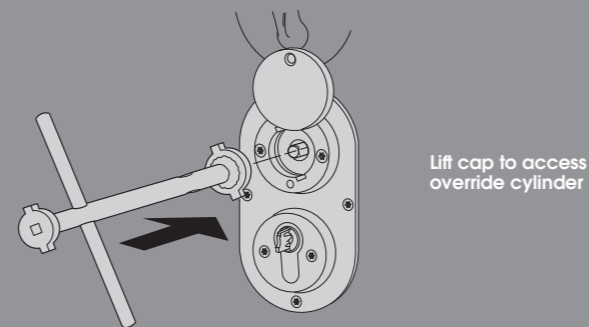

# Protecting Doors

Whether new build or retro-fit we offer solutions for fire doors to reduce maintenance costs, increase the lifespan of both the door and frame whilst retaining fire integrity and aesthetics.

## Door & Frame Protection

Fire Rated products offering outstanding wear and damage protection.

## Privacy Vision Panels

Revolutionary Vision Panels for privacy control and increased visibility.

# Protecting Places

For effective protection of buildings we offer a range of solutions that will minimise maintenance costs whilst providing an aesthetically pleasing look which can be tailored to suit any colour scheme or brand requirements.

## Handrails & Combi-Rails

High level of direct pedestrian guidance and protection against impact from wheeled traffic.

Exclusive UK distributor of



IPC® Door + Wall Protection Systems